

2" & 3" Single Wall Screening Booths



FEATURES

- Acoustic floor with two locking and two non-locking casters
- Prewired jack panel with 1 1/2" diameter pass-thru
- Acoustically engineered integrated ventilation system
- Double glazed, laminated, acoustical safety glass window, 18" (wide) by 24" (high),
- Folding audiometer shelf
- Carpeting with cove base trim
- Fluorescent lighting with switch
- Electrical service via a 12' 12 volt power supply
- Preassembled

OPTIONS

- Vibration isolation system
- Padded stool
- Mobile installation design

The RE-125, RE-126, and RE-130 Screening Booths each provide a self-contained environment for hearing conservation programs. These screening booths, maintained in inventory for responsive delivery, are shipped preassembled with floor-mounted casters which allow for quick set up. The space efficient design fits through most office doors. The booths include built-in ventilation, lighting, and a pre-wired jack panel.

The RE-130 screening booth, built with 3-inch thick panels, provides a higher degree of noise reduction for testing environments with inconsistent ambient conditions.

Acoustic Systems manufactures a wide range of modular acoustic enclosures for audiology programs. The enclosures offer varying levels of acoustic performance, variations in floor plans, and numerous appearance options. Factory trained sales and service representatives will help you plan your project. Acoustic Systems maintains a NVLAP accredited laboratory (NVLAP Lab Code 100286-0) for constant product research and performance assurance.

2" & 3" Single Wall Screening Booths

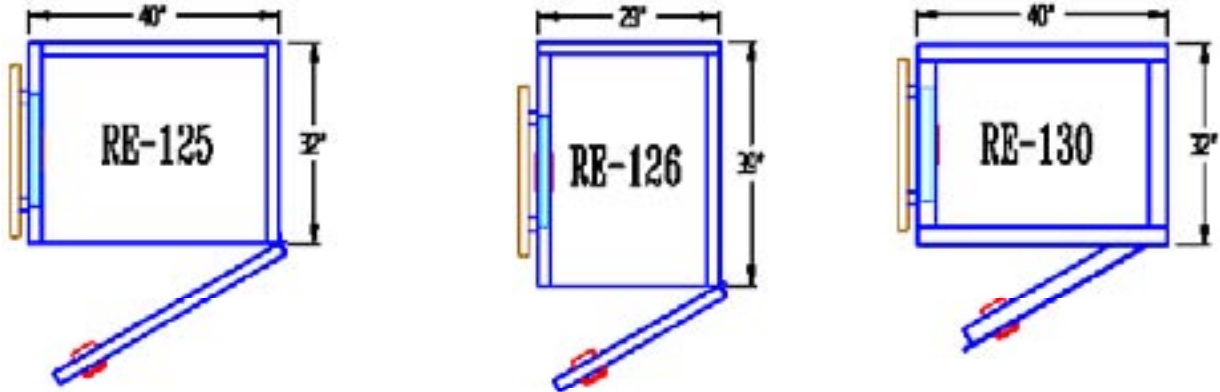

Right hinge door swing shown. Left hinge door swing available.
Window placement always on wall opposite hinge.
Indicate model number and door swing at time of order placement.

MODEL	DIMENSIONS		FEATURES		
	Inside	Outside	Door (Clear Opening)	LIGHTS	WEIGHT
RE-125	28" x 36" x 65"	40" x 32" x 79"	36" (on 40" wall)	1	832
RE-126	34" x 24" x 65"	39" x 29" x 79"	24" (on 29" wall)	1	667
RE-130	26" x 34" x 65"	40" x 32" x 79"	34" (on 40" wall)	1	850

Specifications

Floor and Roof Panels The acoustic roof and floor are 4" thick. The floor rests on two locking and two non-locking casters. For mobile units, the casters are replaced with neoprene, and a door latch and tie-down angles will be provided to secure the booth (by others).

Wall Panels The RE-125 and RE-126 wall panels are constructed of Acoustic Systems' Type 2, 2" thick panels; the RE-130 wall panels are constructed of Acoustic Systems' Type 2, 3" thick panels.

Jack Panel Pre-wired jack panel contains 4 each 1/4" phono stereo plugs and a 1-1/2" diameter pass-thru, with a cover plate. A blank coverplate is included.



Finish Panels are finished with an electrostatic powder coat paint. Color is platinum.

Warranty Single Wall Screening Booths are warranted to be free from defects in material and workmanship, under normal service and use for a period of one year from the date of installation.

Acoustical Performance

Noise Reduction

Center Frequency Hz	500	1000	2000	4000	8000
RE-125/126	38	44	52	53	52
RE-130	42	47	54	56	56

Noise reduction from outside to inside of a properly installed booth in accordance with ASTM E-596

Maximum Permissible Noise Levels from Ventilation Systems

Center Frequency Hz	500	1000	2000	4000	8000
SPL dB	19.5	26.5	28.0	34.5	43.5

Acoustic Systems warrants the maximum octave band noise level shall not exceed ANSI S3.1 ears uncovered levels for a test frequency range of 125 Hz to 8000 Hz provided the booth has been selected appropriately with consideration to the noise and vibration levels of the host environment.



www.acousticsystems.com
info@acousticsystems.com
PO Box 3610 • Austin, TX 78764
512/444-1961 • FAX: 512/444-2282